

A Series Mini Pallet Truck Specification

Distinguishing mark	1.1	Manufacturer	HANGCHA GROUP CO.,LTD.	
		HCFA Model	WP20S	
	1.2	Manufacturer's type designation	CBD20-AMC1	
	1.4	Operator type	Walkie	
	1.5	Rated load	Q (lb)	4000
	1.6	Load centre distance	c (in)	24
	1.8	Load distance, centre of drive axle to fork	x (in)	37.8
Weight	1.9	Wheelbase	y (in)	53.4
	2.1	Service Weight(Including battery)	lb	750
Tires, chassis		Battery weight	lb	176
	3.1	Tires	PU	
	3.2	Tire size, front	in	Ø9.9x3.1
	3.3	Tire size, rear	in	Ø3.1x2.5
	3.4	Additional wheel (dimensions)	in	Ø2.8x1.6
	3.5	Wheels, number front / rear (x = driven wheels)		1x+2/4
	3.6	Tread, front	b ₁₀ (in)	1.7
Dimensions	3.7	Tread, rear	b ₁₁ (in)	15.7
	4.4	Lift	h ₃ (in)	4.7
	4.15	Height, lowered	h ₁₃ (in)	3.1
	4.19	Overall length	l ₁ (in)	68
	4.21	Overall width	b ₁ (in)	26.8
	4.22	Fork dimensions	s/e/l (in)	2.0/6.3/45.3
	4.25	Distance between fork-arms	b ₅ (in)	22
	4.32	Ground clearance, centre of wheelbase	m ₂ (in)	1.2
	4.34.1	Aisle width for pallets 1000 x 1200 crossways	A _{st} (in)	88.2
	4.34.2	Aisle width for pallets 800 x 1200 lengthways	A _{st} (in)	84.6
	4.35	Turning radius	Wa (in)	58.4 ¹⁾
Performance data	5.1	Travel speed, laden/unladen	mile/h	2.5/3.4
	5.2	Lift speed, laden/unladen	ft/min	5.3/7.9
	5.3	Lowering speed, laden/unladen	ft/min	8.3/7.5
	5.8	Max Gradeability, laden/unladen	%	8/15
	Electric engine	6.1	Drive motor rating	hp
6.2		Lift motor rating	hp	1.07
6.4		Battery voltage, nominal capacity	V/Ah	4x12/50
8.1		Type of drive control		Curtis DC

Note: 1) Load section lowered+2.2in;

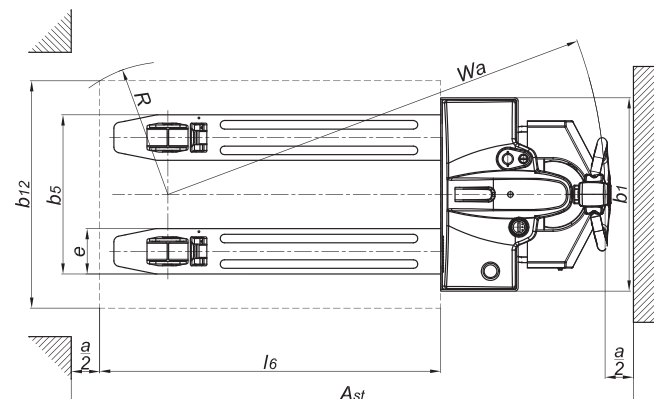
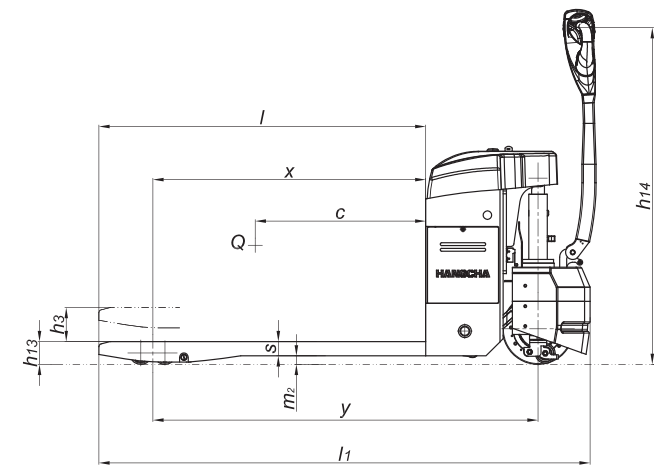

HANGCHA

HC FORKLIFT AMERICA CORPORATION

Company address:
10405-A Granite Street Charlotte,
NC 28273

Toll Free: (888) 652-8395
Phone: (980) 888-8335
Fax: (980) 888-8336

america@hcforklift.com
www.hcforkliftamerica.com



2020 VERSION / COPYRIGHT 2020/03

HANGCHA GROUP CO., LTD. reserves the right to make any changes without notice concerning colors, equipment, or specifications detailed in this brochure, or to discontinue individual models. The colors of trucks, delivered may differ slightly from those in brochures.



A Series Mini Pallet Truck

with capacities of 4,000lbs

The World of Hangcha



A Series Mini Pallet Truck

The A Series 4,000lb Mini Pallet Truck is a new product developed by Hangcha for warehouse and logistics applications. With state-of-the-art permanent magnet brush-less drive technology, and a 48V system, this mini pallet truck features advanced performance, comfortable operation, safety and reliability, and low maintenance cost. The A Series Mini Pallet Jack is an ideal pallet jack for loading, unloading, and handling palletized goods in warehouses, supermarkets, and workshops.

Easy/
Efficiency/
Economy

Appearance

- / The A Series Pallet Truck was designed with the specialized industrial design of appearance in mind. The pallet truck features smooth lines and an affluent sense of movement all found in a compact profile. The truck was designed with full consideration being given to ergonomics.
- / It is manufactured with a large number of steel plate stamping and injection molding technologies while keeping in compliance with environmental requirements. This gives the truck solidness, durability, and a sense of high quality.

Safety

- / Release braking, reverse braking, and three types of emergency braking ensure safety when operating.
- / The pallet jack does not slide on a slope thanks to regenerative braking ensuring safety during operation.
- / The emergency reverse button at top of the tiller helps to avoid operator injury effectively in case of emergency during the backward operation of the truck.
- / Goods are protected thanks to the electronic lifting limiter and the smart controller limiter found on the standard configuration. These limiters work to avoid impact when the fork is lifted to the top of the mast and offer protection to the motor.

Comfort

- / The REMA Tiller is simple and reliable. It allows the operator to perform all of the operations easily with one hand.
- / The truck is designed to provide a terrific operating view of the truck.
- / The built-in charger and rubber enclosed maintenance-free battery are very convenient to use.
- / Thanks to the truck's small design, operating it is easy, flexible, and extremely convenient. The upright-tiller running function also allows it to work within confined spaces, such as a container.
- / Standard height of the fork is 3.15". A guiding device is implemented to make loading and unloading pallets easier. This works with American closed-deck, and European double-deck pallets).
- / With an integrated battery assembly and nylon guiding device added at the base plate, the battery is easy to swap out.

Reliability

- / The pallet jack has a three-point support design, side support system, and elastic auxiliary wheels to guarantee safety and reliability.
- / With optimized design, the lifting rod is steady and reliable, bearing a small force.
- / All plug connectors are waterproof. All of the wires and cables are also protected to increase the reliability of the electrical system.
- / The cutting-edge, reliable, hydraulic power unit features low noise, small vibration, and provides stable lifting and lowering of loads.
- / Stamped molded fork provides higher strength and impact resistance. They also are more efficient by working together with the fork-tip guiding function.
- / The interlock switch is extremely reliable due to being a non-contact proximity switch.
- / The one-piece iron wheel hood offers protection to the truck body against external impacts.

High Performance

- / The load capacity is 4,000 lbs, which can satisfy the handling demand of most customers.
- / The truck can run for up to 6 hours between charges.
- / Full-load grade-ability of the truck can reach 8%, thanks to its high-performance brush-less drive motor.
- / It is equipped with a permanent magnet brush-less drive motor, with excellent performance. It is also equipped with a new 48V power supply system, with extremely low heat generation.
- / The latest CURTIS permanent magnet brush-less control system offers excellent power, high-efficiency, and stable control performance.
- / The tiller, controller, connectors, battery plug, battery condition meter, timer, and switches are all parts from industry known suppliers to ensure reliability, performance, and ease of service.

Maintenance

- / As as standard configuration, the built-in charger and the gel battery requires no maintenance work.
- / The battery indicator will prompt the user to charge the battery.
- / When the motor cover is opened, the user can clearly see all of the components. This makes maintaining the pallet jack extremely convenient.
- / All rotating shafts are equipped with a lubricating sleeve and oil cup. This is designed to give the rotating shafts a long service life.

Standard Features

- / 48V Permanent Magnet Brush-Less Drive Motor
- / CURTIS Permanent Magnet Brush-Less Controller
- / VIBO Hydraulic Power Unit
- / Emergency Cut Off Switch
- / Battery Indicator
- / Polyurethane Wheels
- / 48" Fork Length
- / 27" Outer Distance Between Forks
- / 3.15" Distance From Fork Surface to Ground
- / Electronic Lifting Limit
- / Non-Contact Interlock Switch
- / REMA Multi-Function Tiller Head
- / Horn
- / Maintenance-Free Gel Battery
- / Built-In Charger
- / Upright-Tiller Creep Speed Running
- / Elastic Additional Wheels
- / Single Load Wheels

Options

- / Various Fork Lengths
- / Various Outer Distances Between Forks
- / Tandem Load Wheel
- / Coded Lock
- / 2.95" Ground Clearance



Rema Multi-Function Tiller Head



Additional Wheels are Equipped to Increase Stability



Battery Side Roll Out



Modern Industrial Design